

NATIONAL RESEARCH PROJECT FOR SIMULATED RAINFALL - SURFACE RUNOFF STUDIES

PROTOCOL

The field objectives of the National Phosphorus project are to characterize soil test P (STP) - runoff P relationships for a representative cross-section of important agricultural soils across all Major Land Resource Areas in the U.S. Soils subject to past manure additions from the range of major animal production systems (i.e. dairy cattle, beef cattle, hogs, poultry, etc.), will be covered. These soils will be located in watersheds contributing to the range of different types of water bodies and different climatic regions. The initial goal of the National Phosphorus Research Project is to relate soil test P and surface runoff P, with other confounding factors such as fertilizer or manure application minimized. However, while the plots are in place and after they have been rained on several times, it is the perfect time to apply fertilizer or manure as per location guidelines and expand the research program.

Plot establishment

- Select area for plot establishment on slopes typical of the benchmark soil, but with sufficient slope (>2%) to generate runoff; avoiding sites with significant depression storage areas; select cropping system with typical percent cover; and either identify sites with a preexisting range of STP levels or adjust STP levels (see below).
- Construct runoff plots at each site with dimensions of 2 m long and width of 0.75 to 2 m. The long axis should be oriented down the slope. Under situations of intrasite variability, plots should be 1.5- to 2-m wide by 2-m long. Preliminary studies have shown a minimum of 10 paired sites are needed to accurately describe the soil - runoff P relationship.
- Install metal borders (0.08 inch thick and six inches wide) 5 cm above the ground to isolate surface runoff.
- Install runoff collection gutter at the down slope edge of each plot to divert runoff to a collection point. See Figure 1.

- If plots are established in pastures, mow the plots to a uniform height of approximately 10 cm, one week before the rain simulation and remove the grass clippings.

Adjustment of soil P levels

- Identify sites that provide a range of STP levels on the same soil due to previous manure and fertilizer applications by the landowner, with no P applied in the previous nine months.
- Adjust STP levels of individual plots to obtain a STP range from “low” to “very high” by additions of manure. Levels that qualify as “low” and “very high” may depend on the location and extractant used. In pasture situations, adjustment of STP levels may require several applications of manure to the same plot with follow-up soil testing to ensure attainment of the desired levels, and adjustments may take up to a year or longer to accomplish. In tillage situations, STP adjustments could be done more quickly because more manure could be applied and incorporated at each application.

Soil sampling

- The simplest method is to collect and bulk in the field, 10 cores for each sampling depth (0-5 and 0-15 cm) from within each plot, after raining.
- A more rigorous approach is to air dry the 10 cores and mix equal weights of each core thoroughly to form a composite sample. Run analyses on composite sample, and, if necessary, determine variation in properties from individual samples.

If collection of individual cores and bulking after air drying is impractical, participants should note that variability in single sample volumes may result in significant, unpredictable sampling error. This error can affect associations between STP and runoff P, resulting in poor correlation of these variables. We feel that at a minimum, a consistent sampling and bulking method must be used throughout your study.

- If the plots are to be used in subsequent manure management studies, then soil samples should be taken outside but adjacent to the plots. If soil cores are taken inside the plot, the insitu hydrologic properties of the plots will be destroyed.

Soil analyses

- Air dry soil samples and sieve (2-mm) to remove larger rock particles and most of the grass thatch material.
- Analyze the samples using one or more of the extractants appropriate for your area, e.g., Texas A&M, Mehlich III (Mehlich, 1984), Bray-Kurtz P1 (Bray and Kurtz, 1945), Olsen (Olsen et al., 1954), Fe oxide-impregnated paper strip (Sharpley, 1993), distilled water (Pote et al., 1996), and ammonium oxalate (Sheldrick, 1984; Pote et al., 1996).
- Archive remaining soil sample for further analysis.

Source-water testing

- Collect sample of the source water to be used for the rain simulations.
- Perform as complete analysis of the source water as possible to gain a perspective of the general quality of the source water. Conductivity, pH, and ICAP (inductively coupled argon plasma spectrometer) analysis will provide a perspective of the overall quality and concentrations of potential cations (Al, Fe, Ca) that could interact with the phosphate ion.
- Test source water (outlined below) to determine if dispersion of soil particles is greater than would be produced by rain water.
 1. In a test tube, mix a sample of the surface soil receiving simulated rainfall into a water sample from the water source to be used. Use a ratio of 1 g of soil for each 8 mL of source water (e.g., 5 g of soil in 40 mL of water). Conduct duplicates.
 2. Repeat above step but substitute deionized water for the source water.
 3. Cap the test tubes and shake for about 30 min on a reciprocating shaker.
 4. Place the test tubes in a rack and let stand motionless for three hours.
 5. Observe any visual difference between the clarity of the suspension between the two treatments (deionized water vs source water).

Assume the deionized water represents low buffered rainwater, serves as the control, and produces little soil dispersion. Most of the solids should settle out in the 3-h period. If the dispersion properties of the source water are similar to the control, then the source water will not affect the dispersion properties of the soil and can be used as source water for

simulated rainfall. If, however, dispersion still exists after 3 h (as evidenced by turbidity in the treatment test tubes), the source water can influence dispersion and an alternative source water should be found.

6. Each soil receiving simulated rainfall should be tested for dispersion effects.
 7. Source water effects on soil P release can be determined by extraction of soil with various source waters (e.g., distilled, tap, ground water, well water, and carbon filtered) at a soil to solution ratio of 1 to 10 for 30 min. The soil to solution ratio and short time approximate suspended sediment concentration of the simulated rainfall-runoff event.
- Transport water to the site (if necessary), preferably not more than 24 h before simulations (Figure 2). Hose reels (Figure 3) can greatly simplify the mechanics of conducting the simulations. Alternatively, cation and anion filters can be attached to the trailer and used on site (Figure 4).

Antecedent moisture

- Determine the antecedent moisture conditions at the site using a soil moisture probe (similar to DELTA-T DEVICES *ThetaProbe*, type ML2). To identify θ corresponding to field capacity, conduct the following analyses:
 1. Position the open end of a plastic bucket (open on each end) in the soil to a depth of about 5 cm to form a watertight seal. Run duplicates.
 2. Gradually add water to the bucket to form a head (~15 cm) and allow to drain.
 3. Repeat the above process several times to ensure saturation and then cover the site with an evaporation barrier (plastic) and wait 48 h. After 48 h, take readings with the *ThetaProbe* and take soil samples (5 cm) for determination of θ .
 4. Allow the system to continue to dry, taking *ThetaProbe* measurements and soil samples for θ determinations. Depending on conditions, this could be one- to two-day intervals.

5. From this data, you will know the θ that represents field moisture content and also be able to construct a graph of the *ThetaProbe* output vs. θ and perform a soil-specific calibration as outlined in the manual.

Rain simulators

- Rain simulators based on design of Miller (1987) and as described by Humphry et al. (2002).
- Each simulator has one TeeJet™ ½HH-SS50WSQ nozzle placed in the center of the simulator and 305 cm (10 ft) above the soil surface. The nozzles and associated water piping, pressure gauge, and electrical wiring are mounted on an aluminum frame. The frame is fitted with tarps to provide a windscreen.
- A pressure regulator is used to establish a water flow rate of 210 mL/sec at each nozzle. The regulator must be placed adjacent (on the same level) to the nozzle on top of the simulator (see Fig. 1). Obtaining the correct flow rate out of the nozzle is the first step to ensuring proper amount and distribution of kinetic energy.
- To determine the uniformity of rainfall distribution over the 4 m² plot area and surrounding area within the simulator foot-print 6.25 m², place collecting cups on less than a 50-cm grid. The collection cups must be no more than 5 cm high, as taller cups reduce the amount of rainfall collected due to nozzle configuration and can underestimate actual amounts.
- Measure flow rate by sticking tube (we use a 10 foot length of 2 inch pvc pipe) around nozzle and collecting effluent from tube. The #50 nozzle should have a flow rate of 210 mL/sec. If a #30 nozzle is used, this should have a flow rate of 125 mL/sec.
- Given the proper flow rate, measure rainfall intensity by pan method, NOT by the cup method. In short, collect rain with a tray that covers the entire area of the runoff plots. Using cups results in an overestimation of rainfall intensity.
- Before each simulation run, center the nozzle over the plot. By knowing the dimensions of your simulator and the position of the nozzle, you can tape (duct-tape) markers on the bars of the simulator so once the simulator is aligned correctly (downslope and across slope) the simulator will be centered.

Cautionary notes on simulator

- The temperature of the water makes a difference. The Arkansas crew did intensity runs with water out of the cold water tap (around 70 F) and got the desired 6.97 cm/h and then changed to the hot water tap. We wanted to know what effect this has because sometime we may fill the tank on Friday for a run on Monday. During that time the water will warm up, relative to the cold water tap. Anyway, you get the picture if you are doing runs in Erath County, TX, with the temperature a chilly 104 degrees! With the hot water, we reduced our intensity to 6.2 cm/h. So, we would recommend collecting the water on the day of the runs rather than several days in advance.
- The ½ HH SS 50WSQ is an industrial nozzle, with a spray angle of 104 degrees plus or minus 5%. The nozzles wear with time, affecting both intensity and uniformity. With use this should be checked and the nozzles changed at least each season.
- The pressure regulator, which is used to set the flow rate and intensity for each simulation, **must** be at the same level as the nozzle.
- The simulator should be entirely enclosed with tarps to minimize wind disturbance of rainfall intensity.

Rain simulation

- If the plots are established in pasture or conservation tillage (residue management) systems, measure the percent cover using the string method (Laflen et al., 1981).
- Evaluate the moisture conditions at the test site as outlined above (**Antecedent Moisture**).
- Conduct the simulation run at an intensity of approximately 70 mm/h. Alternatively, conduct the simulation at an intensity corresponding to a ten-year storm for the location. The 70 mm/h intensity is intended to permit comparisons between sites, whereas the intensity of the ten-year storm is intended to approximate local conditions.
- Two rainfall simulations to be conducted at one-day intervals. The first rainfall is conducted at site soil moisture conditions and time to initiation of surface runoff noted for later evaluation of site hydrologic response. The sites will be at approximately field capacity for the second rainfall.

- Collect runoff *in toto* for 30 min, weigh to determine runoff volume, and take a subsample of the collected runoff. A runoff sample at the end of the 30-minute event should also be collected for analysis to reflect an equilibrium P value. Note: Collection of runoff *in toto* is impractical if plots are much larger than 1 x 2 m, since the runoff volumes produced are large. Alternatively, collect runoff samples of approximately 1 L at 5-min intervals during the runoff event beginning 2.5 min after the start of continuous runoff (six discrete samples / plots / rains), giving a total runoff time of 30 minutes. Record sample volumes and the times required to collect them to calculate the mean runoff flow rates and total runoff volumes and to construct a composite sample from the six discrete samples. The discrete samples can be analyzed individually, but analysis of the flow-weighted composite is less expensive.
- It is recommended that discrete samples be taken during an event for the first few simulations to define the P chemograph. Subsequent simulations only require a single sample of the total flow. This dramatically reduces field and analytical labor and in most cases, a flow-weighted event P concentration will be used.
- Filter (0.45 μ m pore diameter) subsample of each composite sample to remove particulate matter.
- Keep the filtered and unfiltered runoff samples at 4°C until analyzed. Alternatively, acidify the filtered and unfiltered runoff samples with 2 mL of concentrated H₂SO₄.
NOTE: acidification for sample storage will not allow the subsequent determination of algal-available P by either strip or resin membrane methods. Add 1 drop of concentrated H₂SO₄ to each 10 mL of runoff sample to lower pH to approximately 2.
- Analyze soil and water samples as soon as possible or store soil and runoff samples in the dark at 4°C until analyzed.

Runoff Sample Analyses

- Analyze samples following procedures in APHA (1992; Pierzynski, 2000): Dissolved molybdate reactive/soluble P, total dissolved P, total P, bioavailable P, suspended sediment, pH.

Data analyses

- Analyze relationship between STP levels and runoff P concentrations by regression analysis. Develop regressions and correlation coefficients for each soil series. Determine (a) if a significant relationship exists between STP and runoff P levels for each of the soils and (b) if the relationship between STP and runoff P is the same between soils.

INDOOR SOIL BOXES - Rainfall Simulation Protocol

The indoor soil box protocol has been established for specific conditions and objectives. Firstly, when a site is extensively tilled to achieve plot uniformity, it is suggested that similar relationships between soil P and surface runoff P will be obtained with indoor runoff boxes as with field plots. However, it cannot be emphasized strongly enough that indoor boxes are not intended to replace field plots and are to be used in conjunction with field plots. The second scenario under which the indoor boxes may be used is to broaden the selection of soils evaluated. Clearly, the number of field plot sites that can be evaluated over the next two to four years will be limited. The indoor boxes will help strengthen the data base relating soil P and surface runoff P as a function of soil type.

Soil Collection

- Soil from the surface 7.5 cm of selected benchmark soils should be collected in a relatively dry condition with as little residue as possible. The sampled soil depth equates to the depth of soil used in the runoff boxes.
- Physical, chemical, and mineralogical properties are determined on each soil as per National P field protocol.
- Soils are air-dried in the laboratory, then sifted through a 19-mm sieve, and thoroughly mixed. Pretreatment of soil is minimal and a coarse sieve used to retain as much as possible.

Runoff Box Construction

- Use 1-m long, 20-cm wide, and 7.5-cm deep soil boxes, with side and back walls 2.5 cm higher than the soil surface (Figure 5a). The height of side wall is similar to the height of the field plot boundaries and should not result in any rain shadowing effect in boxes not in the center of the rainfall simulator.
- The boxes are constructed with stainless steel, galvanized sheet metal or plywood. The former are more expensive but will be sturdier, easier to clean, and last longer. If made from wood, the side walls, ends and bottom should be screwed and glued together and then caulked from the inside to seal them. The caulking may need to be touched up occasionally. As long as damp soil is not left in the box for a long time after an experiment has been completed, the wooden boxes can last for several years. However, the general consensus of the group is that metal boxes will be easier to maintain and their additional cost is small compared to other project expenditures.
- Drainage holes (5-mm diameter) are located on the base of the box, at upper, mid, and lower locations (Figure 5b). Although this will not replicate field drainage, several group members thought some drainage was necessary and would improve reproducibility. Surface runoff is collected at the down slope end by a V-shaped aluminum trough. The shaped metal is screwed and caulked to the outside lip of the box (see Figure 6). A cover is attached to the end of the side-wall to protect the runoff collector trough from direct input of rainfall.

Packing the Box with Soil

- The box is packed with a predetermined weight of soil, so that the final weight of soil in the box is known and the approximate bulk density of field soil can be achieved. Cheesecloth is placed on the bottom of box, followed by the addition of 5 cm of soil. Soil is usually added several times to achieve the appropriate bulk density. We use a wooden tamper to pack the soil during filling (Figure 5c).
- Soil is added until it is level with the lower lip of the runoff box. After the desired bulk density is achieved by soil addition and tamping, the box is then placed at the required distance below the simulator nozzle (3.05 m or 10 feet). To a certain extent, packing is somewhat subjective depending on the “packer”. However, a personal or individual

protocol is developed after a couple of boxes are packed. Soils will be evaluated in triplicate, so that each soil should be packed into three different boxes for the runoff study.

Simulating Rainfall and Chemical Analyses

- This portion of the protocol closely follows the field protocol discussed previously. Soils are pre-wet to control for antecedent moisture. A furnace filter is placed on the soil surface to protect the soil from raindrop impact, simulating crop cover. The soil is saturated using the rainfall simulator and the furnace filter removed. Saturated soils are left to drain for 24-36 hrs (covered with plastic) until field capacity is achieved. Volumetric soil moisture content is determined by theta probe. Depending on user capabilities and amount of soil, it is recommended that for each soil, a “prewetted” and “air-dried” condition (no prewetting) be evaluated.
- Runoff boxes can be set at two slopes, a field slope and a “common” slope (about 4 to 5%), with the field slope offering comparison with field data, and the common slope enabling comparison across the National P Project. At a minimum, soils should be evaluated under the common slope.
- Rainfall simulations are conducted three times, at one-day intervals between rainfall events to allow the soil to return to field capacity. Rainfall is applied at 70 mm/h until 30 minutes of runoff has been collected (same protocol as for the National P field plots). A single bulk runoff sample (typically 5 to 7 L) is collected for the 30-min event. As per field protocol, discrete samples can be collected during the first few storms to define the P chemograph.
- Runoff volume, sediment yield, and P are measured as defined under the field protocol. Dissolved, algal-available, and total P forms are measured. Soil samples for chemical analysis should be collected from the material during packing. If samples are needed after a rainfall, a sample can be taken from the up-slope end of the box and replaced with a small amount of the original soil. As the boxes are repacked, limited sampling at the upper end of the box will not affect flow pathways as in the field plots.

REFERENCES

- Bray, R.H., and L.T. Kurtz. 1945. Determination of total, organic and available forms of phosphorus in soils. *Soil Sci.* 59:39-45.
- Humphry, J.B., T.C. Daniel, D.R. Edwards, and A.N. Sharpley. 2002. A portable rainfall simulator for plot-scale runoff studies. *Applied Eng. in Agric.* 18:199-204.
- Laflen, J., M. Amemiya, and E.A. Hintz. 1981. Measuring crop residue cover. *J. Soil Water Conserv.* 6:341-343.
- Lemunyon, J.L., and R.G. Gilbert. 1993. Concept and need for a phosphorus assessment tool. *J. Prod. Agric.* 6:483-486.
- Mehlich, A. 1984. Mehlich III soil test extractant: A modification of Mehlich II extractant. *Commun. Soil Sci. Plant Anal.* 15:1409-1416.
- Miller, W.P. 1987. A solenoid-operated, variable intensity rainfall simulator. *Soil Sci. Soc. Am. J.* 51:832-834.
- Olsen, S.R., C.V. Cole, F.S. Watanabe, and L.A. Dean. 1954. Estimation of available phosphorus in soils by extracting with sodium bicarbonate. USDA Circ. 939. U.S. Gov. Print. Office, Washington, D.C.
- Pierzynski, G. 2000. Methods of P analyses for water and soil. SERA-IEG 17 Regional Publication.
- Pote, D.H., T.C. Daniel, A.N. Sharpley, P.A. Moore, Jr., D.R. Edwards, and D.J. Nichols. 1996. Relating extractable soil phosphorus to phosphorus losses in runoff. *Soil Sci. Soc. Am. J.* 60:855-859.
- Sheldrick, B.H. 1984. Analytical methods manual 1984. LRRRI no. 84-30. Land Resour. Res. Inst., Ottawa, Canada.
- Sharpley, A.N. 1993. An innovative approach to estimate bioavailable phosphorus in agricultural runoff by Fe oxide-impregnated paper. *J. Environ. Qual.* 22:597-601.

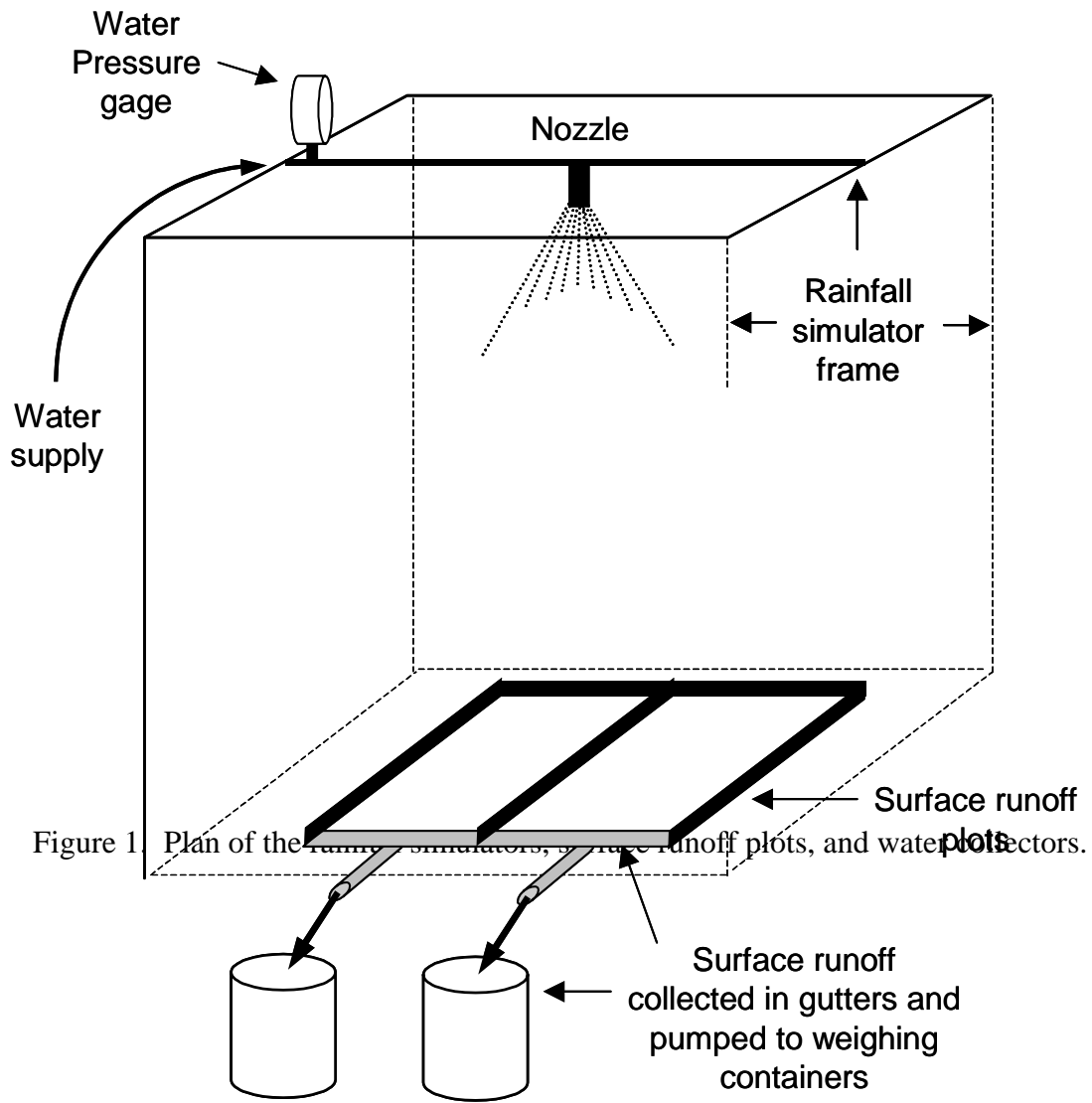

Figure 1. Plan of the rainfall simulator, surface runoff plots, and water collectors.

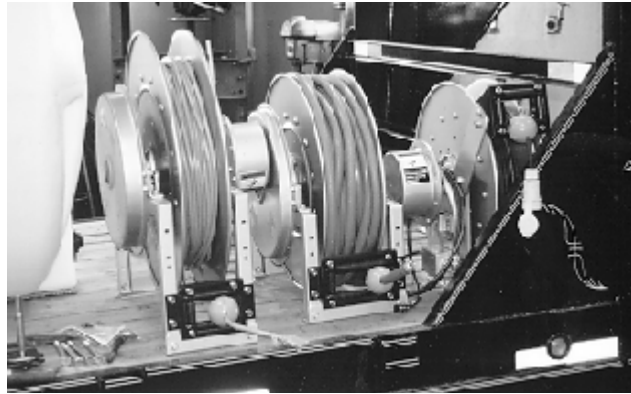

Figure 2. Goose-neck trailer with 1600-gal. capacity water tank. (Chem-tainer Industries, Inc. 361 Neptune Ave. West Babylon, NY 11704, 516-661-8300).



Arkansas prototype



Pennsylvania prototype

Figure 3. Hose reels for power cords, “brain stem,” and water lines. (Hannay Reels, 553 State Route 143, PO Box 159, Westerlo, New York 12193-0159, 518-797-3791, www.hannay.com).



Figure 4. Water filtration tanks on trailer.



Figure 5. Runoff plots inside the simulator aprons.

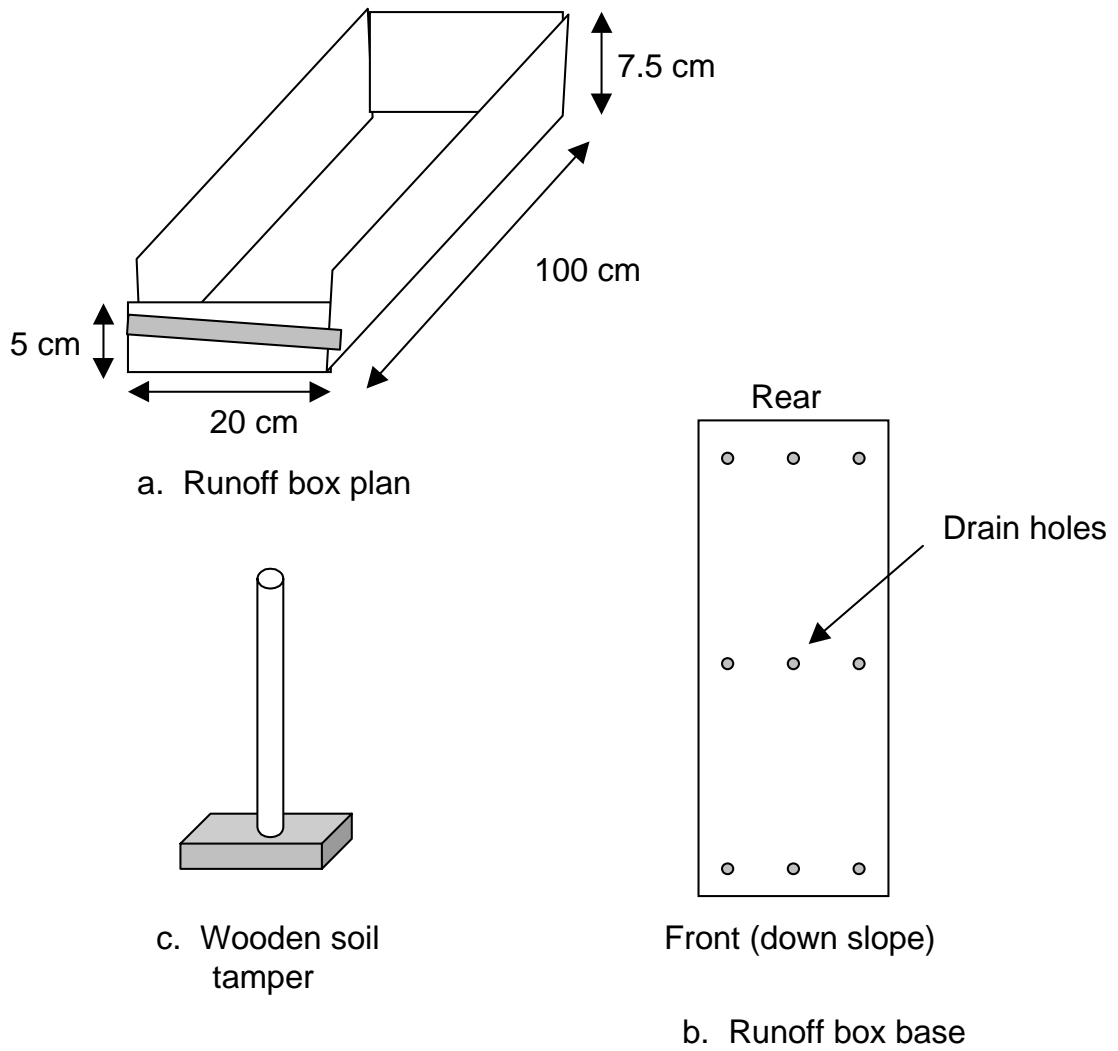

Figure 5. Runoff box plan.

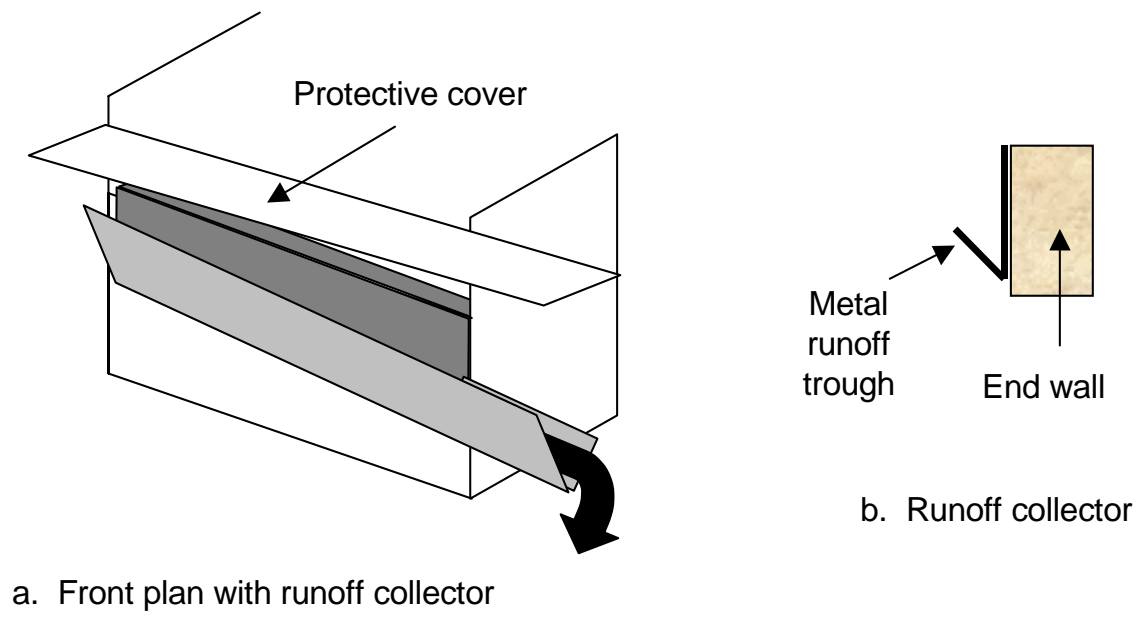

Figure 6. Runoff collection.